



Inox Three function shower system with basin mixer

PRODUCT ID
M392001 D391007
RB.TGN.0BS241.BR.PK

FEATURES

- Body: Brass
- Handle: Zinc alloy
- Shower head (25cm): ABS
- Three functions hand shower: ABS
- Finish: Chrome

INCLUDED COMPONENTS

- | | |
|--|--|
| <p>Mixer:</p> <ul style="list-style-type: none"> • 25mm Sedal Ceramic Cartridge • Neoperl Aerator • A pair of Stainless Steel Tucai Flexible Hoses 1/2" Connection • Fixing kit | <p>Shower:</p> <ul style="list-style-type: none"> • 35mm Sedal Ceramic Cartridge • ABS shower head-25cm • Three functions hand shower • 150cm PVC shower hose 1/2" • Height adjustable hand shower holder • Overhead shower angle |
|--|--|

FLOW RATE: L/MIN

Water pressure	1bar	2bar	3bar	4bar	5bar
Basin mixer	6.6	9.48	11.88	14.4	16.32
Rain shower	5.64	9.24	11.88	13.08	15.12
Hand shower	5.4	8	10.44	12.6	13.32

REMARKS

- Quality standard apply with EN 817 regulation
- Plating thickness passes NSS 200H test under lab conditions

WARRANTY

• ROCELL BATHWARE guarantees all its Chrome plated ranges of mixers and taps for a period of 5 years from the date of purchase against defect of work or materials, except for the electronic parts and the internal components such as ceramic cartridges, handworks, headworks and thermostatic cartridges which are guaranteed for a period of 2 years.

TECHNICAL DRAWINGS

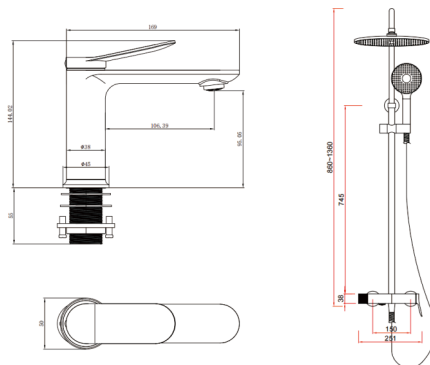

Royal Ceramics Lanka PLC.

No.20, R.A. De Mel Mawatha, Colombo 03, Sri Lanka.

☎ 076 6 223 344 ✉ info@rcl.lk 🌐 www.roccl.com

FOLLOW US



** Dimensions of fixtures are nominal and may vary within the range of tolerance. These measurements are subject to change or cancellation. No responsibility is assumed for use of superseded or voided leaflet.